



## Trident Ringlock, Trident Neptune & TNM

Trident circular connectors are a cost effective, reliable, and aesthetically pleasing method of making connections to and from an electronic package. There are three types of Trident circular connectors: Trident Ringlock, Trident Neptune, and TNM. Trident Ringlock connectors are designed to carry power or control signals and are waterproof up to IP67. Trident Neptune, which is a variation of the Ringlock line, allows mixing of high power and signal contacts within the same connector with amperage up to 30 amps per contact. Neptune is completely sealed and submersible up to IP67 for the most demanding applications. Both Trident Ringlock and Trident Neptune are UL94V0 circular plastic connectors, but with the critical addition of a metal coupling nut and metal bayonet retention mechanism. This unique construction combines

the low cost and weight of a plastic connector with the durability of an all metal connector. The Trident series uses the same contacts and accessories, reducing the number of parts necessary to cover any operating environment. Trident Ringlock connectors are completely interchangeable with Burndy Trim-Trio (UTG) series and use interchangeable contacts. Trident Neptune uses the same contacts as Ringlock, but is a unique product for transportation and harsh environments where full sealing and mixing of power and signal contacts is required.

### Applications

Industrial and vehicular connections to & from electronic cabinets and boxes. Any power and signal application requiring total moisture sealing.

- Trucks & Buses
- Off-road Vehicles
- Rail and Mass Transit
- Marine
- Process Control
- Industrial Machinery
- Control Cables
- Probes
- Hand Controllers
- Remote Sensors
- Inter-system Connections

### Features

#### Strong, Light Weight, Low Cost

Superior to plastic circular connectors and less costly than metal connectors. Trident's metal bayonet coupling nut and locking mechanism provide strength and life comparable to an all metal connector. Bodies are of durable UL94V0 thermoplastic with high strength nickel plated metal coupling nuts and bayonet ring. Molded rubber and silicone seals guarantee water-tightness.

#### Attractive Appearance

Nice enough for front panel mounting

#### Submersible or Waterjet-proof Versions

Neptune uses a rear individual wire sealing grommet and is fully submersible to IP67. Ringlock is protected against submersion to IP67 using gland seal cable clamp.

#### Wide Temperature Range

Trident will operate in temperatures from -55°C to +120°C (-67° to +248°F) under conditions of high humidity, severe vibration, ice and mud.

#### Wide Range of Wire Gauges and Current Carrying Capability

Up to 30 amps per contact with wire sizes from 28 AWG up to 12 AWG wire. New TNM 700 volt 40 amp power for up to 8 AWG.

#### Standard and Reverse Connector Housings

In the Trident STANDARD configuration, the receptacles use socket contacts and the plugs use pin contacts. A REVERSED version is also available for safety and/or polarization. Standard and reversed connectors will not intermate. 'Keying Pins' are also available to polarize connectors with the same orientation and layout used on the same panel to prevent mis-mating.

#### Wide Range of Contact Styles

Contacts are available in crimp, PC, coax, wire wrap or first make/last break for ground connections.



**TNM**  
**(Trident Neptune Metal)**  
See pages 60-63

## Features

### Field Serviceable

The use of removable crimp contacts allows connections to be changed or modified in the field if necessary. Contacts are copper alloy with a range of gold or tin platings.

### Agency Approvals

- UL and CSA (Trident Ringlock)
- IP67 Submersible

## Technical Specifications

### MATERIALS & FINISHES

Shell	UL94V0 thermoplastic with nickel plated copper alloy coupling nut and bayonet lock ring
Contacts	High reliability copper alloy available in two versions, stamped and formed, or machined
Plating	Tin, gold flash, gold (1 micron), heavy gold (3 microns)
Seals	Rubber, silicone

### ELECTRICAL DATA

Operating Voltage	Up to 250 Vac rms degree of pollution permitting per IEC664 (TNM 700 volt power version)
Test Voltage	2000 Vac rms test potential
Current rating	30 Amps (Neptune Power contacts), 13 Amps (Signal contacts). 16 Amp contacts available. Use in accordance with derating curve, on fold out <a href="#">▶ page 57</a> New TNM 40 amp power.
Wire Range Sizes	28 - 14 AWG (stamped contacts), 28 - 16 AWG (machined), 18 -12 AWG (Power Neptune) 16-8 AWG (Power TNM)
Contact Resistance	5 Milliohms Initial
Insulation Resistance	5000 Megohms at 500Vdc

### MECHANICAL

Operating Temperature	-55° to +120°C (-67° to +248°F). 105°C maximum when 4 or more contacts are run near their maximum current. 105°C maximum when using tin contacts.
Sealing	Up to IP67
Wire Sealing Range	See column 9 on contact selection chart, <a href="#">▶ page 59</a>
Insulation Strip Lengths	See column 8 on contact selection chart, <a href="#">▶ page 59</a>
Mating Life	500 cycles (machined contacts) 200 cycles (stamped)
Salt Spray	To MIL-STD-1344 Method 1001 (48 hrs. no corrosion)
Heat	Damp Heat to BS 2011 Pt2 Ca, 21 days exposure +105°C to -50°C (5 cycles) remains within specifications
Chemical Resistance	Connectors show no damage when exposed to fluids used in industrial/vehicle applications.
Vibration	5 to 55 Hz (1 minute) No discontinuities longer than 1 microsecond
Shock	50g 11ms MIL-STD-202 Method 213 condition A
Contact Type	Crimp, PC, first make/last break, co-ax, wire wrap
Number of Circuits	4 to 48
Contact Insertion	From rear. No insertion tool needed. Removable with proper extraction tool (front release).

# Technical Specifications

Contact Retention

CONTACT	FORCE (min)	
	Lbs.	Newtons
Machined	25	110
Stamped	15	65

Polarization	Standard or reversed sex shells and/or keying pins
Agency Listing	UL (E102053), CSA (LR68300), TNM: UL, C-UL, E151413
Color	Silver (TNM) or Black with silver coupling nut and ring (Ringlock and Neptune)

## Exploded View

### Neptune

**PLUG**

STANDARD ENDBELL (INCLUDED)  
INDIVIDUAL WIRE SEALING GROMMET  
SHELL  
METAL COUPLING NUT

**FLANGED RECEPTACLE**

INTERNAL O-RING (NOT VISIBLE)  
METAL BAYONET LOCK  
SHELL  
INDIVIDUAL WIRE SEALING GROMMET  
STANDARD ENDBELL (INCLUDED)

**JAM NUT RECEPTACLE**

JAM NUT  
INTERNAL O-RING (NOT VISIBLE)  
METAL BAYONET LOCK  
SHELL  
INDIVIDUAL WIRE SEALING GROMMET  
STANDARD ENDBELL (INCLUDED)

### Ringlock

**PLUG**

ENDBELL (VARIOUS OPTIONAL STYLES)  
SHELL  
METAL COUPLING NUT

**FLANGED RECEPTACLE**

INTERNAL O-RING (NOT VISIBLE)  
METAL BAYONET LOCK  
SHELL  
ENDBELL (VARIOUS OPTIONAL STYLES)

### TNM

**PLUG**

STANDARD ENDBELL (Optional)  
INDIVIDUAL WIRE SEALING GROMMET (Optional)  
NICKEL PLATED CONDUCTIVE CAST ZINC SHELL  
METAL COUPLING NUT

**FLANGED RECEPTACLE**

INTERNAL O-RING (NOT VISIBLE)  
METAL BAYONET LOCK  
INDIVIDUAL WIRE SEALING GROMMET (Optional)  
NICKEL PLATED CONDUCTIVE CAST ZINC SHELL  
STANDARD ENDBELL (INCLUDED) (Optional)

**NEW! Light Rope**

**NEW! High Power**

**NEW! 700 Volt High Power**

Connectors				Seal	Gaskets	Endbells					Dust Caps			
<p>Mates With</p> <p>Plug (Sockets) (Neptune version pictured)</p> <p>Flanged Receptacle (Pins)</p> <p>Jam Nut Receptacle (Pins)</p>				<p>Neptune Wire Sealing Range inches (mm)</p> <p>Min OD    Max OD</p>	<p>**For Jam Nut</p> <p>* For Flanged</p>	<p>Ringlock</p> <p>Externally Grooved for Heat Shrink</p>	<p>Neptune</p> <p>Heat Shrink Boot or Flex Tubing †</p>	<p>Waterproof Gland Seal Endbell •</p>	<p>Standard Strain Relief (unsealed)</p>	<p>Low Profile 90°</p>	<p>(Also fits KPT/KPSE Series)</p> <p>Receptacle Metal Dust Cap</p> <p>Receptacle Plastic Dust Cap</p> <p>Plug Plastic Dust Cap ‡</p>			
REVERSE SEX														
Plug (Sockets)	Plug (Sockets) Plastic Coupling Nut	Flanged Receptacle (Pins)	Jam Nut Receptacle (Pins)	Min OD	Max OD									
192926-0500	-	192990-1760	-	N/A		075-8543-011	192990-1430	-	192990-1530	192922-1310	-	192922-1480	192900-0376	192900-0385 Δ
192990-1390	-	192990-1800	-	N/A		075-8543-015	192990-1470	-	192990-1570	192990-1510	-	192990-1410	192900-0380	192900-0389 ΔΔ
192926-0510	-	192990-1770	-	N/A		075-8543-012	192990-1440	-	192990-1540	192922-1320	-	192922-1490	192900-0377	192900-0386 ΔΔ
192926-0520	-	192990-1780	-	N/A		075-8543-013	192990-1450	-	192990-1550	192922-1330	-	192922-1500	192900-0378	192900-0387 ΔΔ
192900-0236	-	192900-0256	192900-0266	.067 (1.7)	.106 (2.7)	192900-0565* 192900-0457**	-	-	192900-0496	192900-0286	192991-0579	192922-1500	192900-0378	192900-0387 Δ
192900-0581	192900-0562	192900-0582	192900-0583	Signal: .067 (1.7) .106 (2.7) Power: .106 (2.7) .157 (4.0)		192900-0566* 192900-0402**	-	192991-0015	192900-0497	192900-0343	192991-0580	192922-1510	192900-0379	192900-0388
192926-0530#	-	192990-1790#	-	N/A		075-8543-014	192990-1460	-	192990-1560	192922-1340	-	192922-1510	192900-0379	192900-0388
192900-0057	192900-0558	192900-0078	192900-0353	.067 (1.7)	.106 (2.7)	192900-0566* 192900-0402**	-	192991-0015	192900-0497	192900-0343	192991-0580	192922-1510	192900-0379	192900-0388
192990-1380	-	192990-1810	-	N/A		075-8543-015	192990-1470	-	192990-1570	192990-1510	-	192990-1410	192900-0380	192900-0389 Δ
192900-0054	192900-0540	192900-0069	192900-0071	Signal: .067 (1.7) .106 (2.7) Power: .106 (2.7) .157 (4.0)		192900-0567* 192900-0458**	-	192991-0013	192900-0498	192900-0344	192991-0581	192900-1420	192900-0383	192900-0392
192926-0540	-	192990-1820	-	N/A		075-8543-016	192990-1480	-	192990-1580	192922-1350	-	192922-1520	192900-0381	192900-0390 Δ Δ
192900-0056	192900-0541	192900-0075	192900-0077	Signal: .067 (1.7) .106 (2.7) Power: .106 (2.7) .157 (4.0)		192900-0567* 192900-0458**	-	192991-0013	192900-0498	192900-0344	192991-0581	192990-1420	192900-0383	192900-0392
192900-0055	192900-0550	192900-0072	192900-0074	Signal: .067 (1.7) .106 (2.7) Power: .106 (2.7) .157 (4.0)		192900-0567* 192900-0458**	-	192991-0013	192900-0498	192900-0344	192991-0581	192990-1420	192900-0383	192900-0392
192926-0550	-	192990-1830	-	N/A		075-8543-017	192990-1490	-	192990-1590	192922-1360	-	192922-1530	192900-0382	192900-0391 ΔΔ
192990-1400	192900-0554	192990-1840	-	N/A		075-8543-018	192990-1500	-	192990-1600	192990-1520	-	192990-1420	192900-0383	192900-0392
192900-0425 192991-0648 (L)	192900-0542 192991-0664 (L)	192900-0431 192991-0652 (L)	192900-0437 192991-0656 (L)	.063 (1.6) .087 (2.2) .090 (2.3) .126 (3.2)		192900-0567 192900-0458**	-	192991-0013	192900-0498	192900-0344	192991-0581	192990-1420	192900-0383	192900-0392

# Mates with TNM, but not with Neptune version

† See Accessories [pages 258-263](#) for heat shrink boots and tubing. ‡ Plug cap can be panel mounted and used as a dummy receptacle. Call for instructions.  
• See [page 67](#) for cable sealing range.

Δ Large minimums may apply to these caps

## Current Rating (By Ambient Temperature)

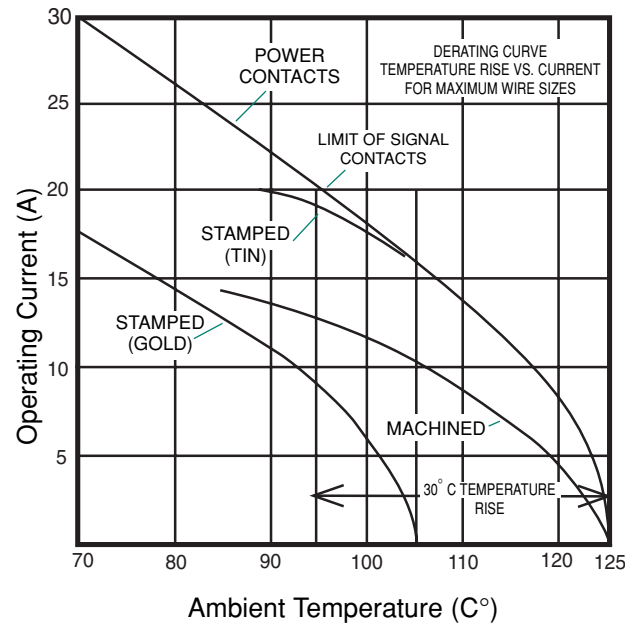

Curves apply to single contacts in isolation. Use of smaller wire gauges or more than one contact in a connector requires derating.

Call for additional derating information.

### How to Select Trident Connectors (Refer to Chart on preceding foldout)

- Determine number of circuits required per connector (4 to 48). Note that some Neptune layouts (shaded rows) have a mixture of power and signal contacts.
- Choose Trident Ringlock (waterjet proof) or Neptune (submersible). Neptune part numbers are shaded in chart.
- Select connector sex: STANDARD or REVERSED. Standard plugs have pin contacts, receptacles have sockets. Reversed plugs have socket contacts, receptacles have pins.
- Choose shell style: PLUG, FLANGED RECEPTACLE, or JAM NUT.
- Find part number on chart (remember, shaded part numbers are NEPTUNE).
- Select endbell, if needed. Neptune comes with low profile wire seal endbell; however, all endbells shown can be optionally used with Neptune connectors.
- Choose dust cap, if required.
- Select contacts and tooling below.

### How To Select Trident Contacts (Refer to Chart on next page)

- Choose stamped or machined contacts.
- Choose contact type: crimp, PC, Power, first make/last break.
- Find your desired wire gauge in COLUMN 2.
- Choose contact plating in COLUMN 3.
- Select part number from COLUMNS 4, 5, 6, or 7.
- Select wire hole filler plugs (if needed) from COLUMN 10. Hole filler plugs are for Neptune version only (gray shaded connectors). Hole fillers are only used to re-seal unused grommet cavities that were punched out, but will not be filled with a wire.
- Select Keying pins (if needed) from COLUMN 11.
- Choose proper crimp tool for your contact from COLUMNS 12 thru 14.
- Choose proper extraction tool from COLUMN 15 (insertion tool not needed).
- Wire strip lengths and insulation dimensions are in COLUMNS 8 and 9.

Trident

## Contacts (1)

COLUMN 1	COLUMN 2	COLUMN 3	COLUMN 4	COLUMN 5	COLUMN 6	COLUMN 7
Trident Contacts	A.W.G. Wire Size	Plating	Loose Pins	3K Reel Pin	Loose Sockets	3K Reel Sockets
<b>STAMPED CRIMP</b>						
<b>13 Amp-200 insertions</b>	24-26 24-26	Tin Gold flash Gold	192990-0020 192990-0080 192900-0448	192990-2510 192990-2650 192900-0406	192990-0030 192990-0090 192900-0452	192990-2550 192990-2690 192900-0410
	20-22	Tin Gold flash Gold	192990-0040 192922-1460 192900-0447	192990-2500 192990-2640 192900-0405	192990-0050 192922-1470 192900-0451	192990-2540 192990-2680 192900-0409
	16-20	Tin Gold flash Gold	192990-0060 192990-0100 192900-0446	192990-2490 192990-2630 192900-0404	192990-0070 192990-0110 192900-0450	192990-2530 192990-2670 192900-0408
<b>Non-insulation support</b>	14 14 14	Tin Gold flash Gold	192990-1240 192990-1220 192900-0445	192990-2480 192990-2620 192900-0403	192990-1250 192990-1230 192900-0449	192990-2520 192990-2660 192900-0407
<b>MACHINED CRIMP</b>						
<b>13 Amp-500 insertions</b>	24-28 24-28 24-28	Gold flash Gold Heavy Gold	192991-0099 192991-0100 192991-0101		192991-0036 192991-0042 192991-0054	
	24 24 24	Gold flash Gold Heavy Gold	192991-0091 192991-0092 192991-0093		192991-0037 192991-0043 192991-0055	
	22 22 22	Gold flash Gold Heavy Gold	192991-0095 192991-0096 192991-0097		192991-0038 192991-0044 192990-0056	
	20 20 20	Gold flash Gold Heavy Gold	192991-0127 192991-0128 192991-0129		192991-0039 192991-0045 192991-0057	
	20 20 20	Gold flash Gold Heavy Gold	192991-0087 192991-0088 192991-0089		192991-0040 192991-0046 192991-0058	
	16-18 16-18 16-18	Gold flash Gold Heavy Gold	192991-0083 192991-0084 192991-0085		192991-0041 192991-0047 192991-0059	
<b>MACHINED SOLDER FOR PROTOTYPING</b>						
<b>28-14 AWG wire</b>						
	<b>Pin</b>	<b>Socket</b>				
Tin	192900-0632	192900-0634				
Gold	192900-0633	192900-0635				
<b>FIRST MAKE/LAST BREAK MACHINED CRIMP</b>						
<b>13 Amp-500 insertions</b>	20 20 20	Tin Gold flash Gold	192991-0166 192991-0163 192991-0164		192991-0211 192991-0078 192991-0207	
	16 16 16	Tin Gold flash Gold	192991-0162 192991-0159 192991-0160		192991-0212 192991-0079 192991-0208	
<b>PRINTED CIRCUIT BOARD CONTACTS</b>						
<b>13 Amp-500 insertions</b>	PC post dia. inches (mm) .043 (1.10) .043 (1.10) .03 (.76) .03 (.76) .028 (.71) .028 (.71) .059 (1.50)	Tin Gold Tin Gold Tin Signal Gold Signal Tin Power	192991-0198 192991-0195 192991-0122 192991-0119 192900-0465 192900-0356 192991-0617		192991-0204 192991-0067 192991-0203 192991-0066	
	<b>Stamped PC pin contacts available, please call.</b>					
<b>POWER STAMPED 30 Amp-200 insertions</b>						
	16-18 14-16 12-14	Tin Tin Tin	031-8717-020 031-8717-021 031-8717-022	121668-0000 121668-0001 121668-0002	031-8717-120 031-8717-121 031-8717-122	121668-0100 121668-0101 121668-0102
<b>COAX/TWISTED PAIR Used only in signal contact cavities</b>						
	Outer Female Contact Assembly	Twisted Pair (B)	192945-4530		192945-4930	
	Outer Male Contact Assembly	Coaxial (A)	192945-4390		192945-4380	

#### (1) Loose or 3K Reel

Stamped contacts are available loose piece or on continuous reels of 3,000 for use with semi-automated crimping systems. Call for information.

#### (2) Wire Hole Fillers (Neptune only)



The rear Neptune wire seal has individual wire seals that are punched out when inserting the contact. If a seal is accidentally pierced, the seal can be repaired by inserting a wire hole filler.

#### (3) Keying Pins

A plastic pin which can be snapped into an unused signal or power contact hole. This will only allow another connector to mate if there is an empty hole opposite the keying pin. Used to polarize similar connectors to avoid mis-mating.

#### (4) Hand Crimp Tool & Locator

Hand crimp tools produce consistent, high quality crimps by using a ratchet mechanism which will only release the contact when

Wire Range		Accessories		Tools			
 COLUMN 8	 COLUMN 9	COLUMN 10	COLUMN 11	COLUMN 12	COLUMN 13	COLUMN 14	COLUMN 15
Wire Strip Lengths Inches (MM) +.02 +.01	Wire Insulation Diameter Inches (MM)	Wire Hole Fillers Neptune Only <sup>(2)</sup>	Keying Pins <sup>(3)</sup>	NEW: See Page 69, Automatic Crimp Tooling		Economy Non-Ratcheting Hand Crimp Tool <sup>(5)</sup>	Extraction Tool <sup>(6)</sup>
<b>Hand Crimp Tool<sup>(4)</sup></b>							
.16 (4.0)	.035 - .0627 (.89 - 1.58)	192991-0018	192990-0000	121586-5236 (20-26 AWG)		192922-1440	192922-1450
		192991-0018	192990-0000			192922-1440	192922-1450
		192991-0018	192990-0000			192922-1440	192922-1450
.16 (4.0)	.046 - .081 (1.17 - 2.08)	192991-0018	192990-0000	121586-5237 (16-18 AWG)		192922-1440	192922-1450
		192991-0018	192990-0000			192922-1440	192922-1450
		192991-0018	192990-0000			192922-1440	192922-1450
.16 (4.0)	.078 - .118 (2.00 - 3.00)	192991-0018	192990-0000	121586-5238 (14-16 AWG)		192922-1440	192922-1450
		192991-0018	192990-0000			192922-1440	192922-1450
		192991-0018	192990-0000			192922-1440	192922-1450
.22 (5.6)	N/A No insulation grip	192991-0018	192990-0000			-	192922-1450
		192991-0018	192990-0000			-	192922-1450
		192991-0018	192990-0000			-	192922-1450
<b>Locator<sup>(4)</sup></b>							
.20 (5.0)	.035 - .055 (.90 - 1.40)	192991-0018	192990-0000	AF8	TH206	-	192922-1450
		192991-0018	192990-0000	AF8	TH206	-	192922-1450
		192991-0018	192990-0000	AF8	TH206	-	192922-1450
.20 (5.0)	.041 - .062 (1.05 - 1.60)	192991-0018	192990-0000	AF8	TH206	-	192922-1450
		192991-0018	192990-0000	AF8	TH206	-	192922-1450
		192991-0018	192990-0000	AF8	TH206	-	192922-1450
.20 (5.0)	.062 - .084 (1.60 - 2.15)	192991-0018	192990-0000	AF8	TH206	-	192922-1450
		192991-0018	192990-0000	AF8	TH206	-	192922-1450
		192991-0018	192990-0000	AF8	TH206	-	192922-1450
.20 (5.0)	.051 - .070 (1.30 - 1.80)	192991-0018	192990-0000	AF8	TH206	-	192922-1450
		192991-0018	192990-0000	AF8	TH206	-	192922-1450
		192991-0018	192990-0000	AF8	TH206	-	192922-1450
.20 (5.0)	.062 - .082 (1.60 - 2.10)	192991-0018	192990-0000	AF8	TH206	-	192922-1450
		192991-0018	192990-0000	AF8	TH206	-	192922-1450
		192991-0018	192990-0000	AF8	TH206	-	192922-1450
.28 (7.1)	N/A No insulation grip	192991-0018	192990-0000	AF8	TH206	-	192922-1450
		192991-0018	192990-0000	AF8	TH206	-	192922-1450
		192991-0018	192990-0000	AF8	TH206	-	192922-1450
.20 (5.0)	.062 - .082 (1.60 - 2.10)	192991-0018	192990-0000	AF8	TH206	-	192922-1450
		192991-0018	192990-0000	AF8	TH206	-	192922-1450
		192991-0018	192990-0000	AF8	TH206	-	192922-1450
.28 (7.1)	N/A No insulation grip	192991-0018	192990-0000	AF8	TH206	-	192922-1450
		192991-0018	192990-0000	AF8	TH206	-	192922-1450
		192991-0018	192990-0000	AF8	TH206	-	192922-1450
N/A	N/A		192990-0010 pin	-	-	-	192922-1450
			192990-7650 skt	-	-	-	192922-1450
				-	-	-	192922-1450
<b>Hand Crimp Tool<sup>(4)</sup></b>							
.20 (5.0)	.055-.079 (1.4 - 2.0) .079-.114 (2.0 - 2.9) .114-.142 (2.9 - 3.6)	192991-0019	192900-0189	112108-0012		192922-1440	192900-0176
		192991-0019	192900-0189	112108-0012		192922-1440	192900-0176
		192990-0019	192900-0189	112108-0011		192922-1440	192900-0176
<b>Hand Crimp Tool<sup>(4)</sup></b>				<b>Locator<sup>(4)</sup></b>			
Call for data sheet containing wire preparation information, tooling, and cable types.			Inner Conductor	AFM8	K151		192922-1450
			Outer Conductor	GS100-1	GP295		

the crimp is completed. Stamped contacts use a tool with integrated dies. Machined contacts use a military style tool (MIL-C-22520/1) which also requires the appropriate locator to form a complete crimping system.

**(5) Economy Crimp Tool (stamp contacts only)**

This is a pliers style tool for prototype or service use. It has no ratchet and the completed crimp requires two separate operations, one to crimp the conductor, and a second crimp to secure the insulation support. The economy tool covers wire gauges 16, 20, and 24 AWG and is for use with stamped contacts only.

**(6) Extraction Tool**

Contacts can be easily removed by placing the extraction tool over the contact in the front of the connector and pushing. The contact is ejected from the rear of the connector. No insertion tool is needed for any Trident contacts.

# Index

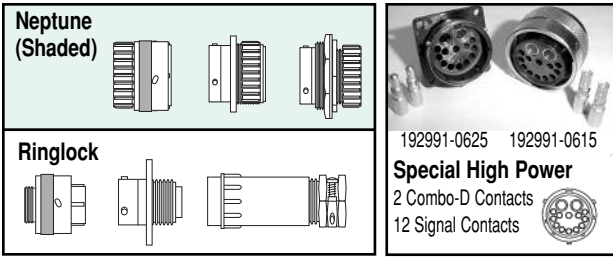

# Connectors

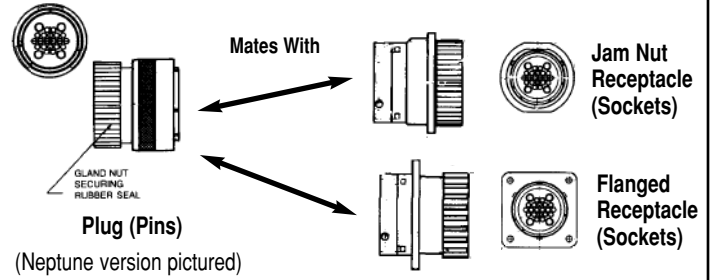

## STANDARD SEX

Layouts	Total Number of Circuits	Number of Power Contacts	Number of Signal Contacts	Shell Size	Plug (Pins)	Plug (Pins) Plastic Coupling Nut	Flanged Receptacle (Sockets)	Jam Nut Receptacle (Sockets)
	4	0	4	10	192922-1250	-	192990-1660	-
	7	0	7	18	192990-1330	-	192990-1700	-
	8	0	8	12	192922-1260	-	192990-1670	-
	12	0	12	14	192922-1270	-	192990-1680	-
	12	0	12	14	192900-0303	-	192900-0308	192900-0313
	15	2	13	16	192900-0507	192900-0561	192900-0509	192900-0508
	19	0	19	16	192922-1280 <sup>#</sup>	-	192990-1690 <sup>#</sup>	-
	19	0	19	16	192900-0017	192900-0557	192900-0039	192900-0490
	23	0	23	18	192990-1320	-	192990-1710	-
	24	4	20	24	192900-0014	192900-0537	192900-0030	192900-0032
	28	0	28	20	192922-1290	-	192990-1720	-
	31	12	19	24	192900-0016	192900-0538	192900-0036	192900-0038
	32	4	28	24	192900-0015	192900-0549	192900-0033	192900-0035
	35	0	35	22	192922-1300	-	192990-1730	-
	48	0	48	24	192990-1340	192990-0553	192990-1740	-
	48	0	48	24	192900-0469 192991-0628 (L)	192900-0539 192991-0660 (L)	192900-0475 192991-0640 (L)	192900-0481 192991-0644 (L)

Mating face of plug for Standard Sex is shown. Reverse Sex have mirror image cavity identification.

+2 COAX / Power +12 signal  
Ringlock version call for details.

**Shaded columns = Neptune Version - Supplied with individual wire seal**

# TNM Connectors



The TNM range of connectors is an extension of the long established Neptune and Trident Ringlock connector series but with the advantage of a number of additional features. These include RF shielding and moisture sealing to IP67.

The connectors feature strong nickel-plated zinc alloy shells with a metal coupling ring for high reliability and durability. When used with the new low cost shielded endbells the connector system provides RF shielding from cable to equipment or cable to cable that satisfy EMC requirements.

The signal contacts used are from the standard Trident contact range (See [pages 58-59](#)). The recommended contacts are the stamped and formed Two Part, available with either tin or gold plated finish. If a higher performance is required the Trident Three Part machined contacts can be used. All signal contacts have a current rating of 13 Amps and wires with conductors 14 - 28AWG (2.50 mm<sup>2</sup> - .08 mm<sup>2</sup>) can be accommodated. Note if more than 4 contacts per connector are designed to run at, or near, their full rated current for sustained periods, a derating factor must be applied. For further details please call 800-523-0727.

## Layouts

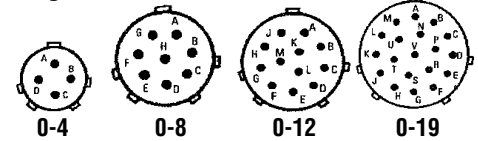

**TNM 700 Volt Power Connector System**  
Shell Size 16

## Power Contact TNM 700 Volts only

Type	Sockets	Pins	Amp Max.
Solder	DM53744-1	DM53745-1	40
Crimp 8-10Awg	DM130341-4	DM130338-4	40
Crimp 12-14Awg	DM130342-4	DM130339-4	20
Crimp 16-18Awg	DM130343-4	DM130340-4	10

Mating face of plug for standard sex is shown. Reverse sex have mirror image cavity identification.

See Technical Specifications [pages 52 and 53](#)



Sealed Plug



Sealed Flanged Receptacle



Unsealed Plug †



Unsealed Flanged Receptacle †

Number of Contacts	Shell Size	STANDARD SEX		REVERSE SEX		Wire Sealing Range for Sealed Versions inches (mm)	Gaskets	Standard Plastic Unsealed Endbell
		Plug (pins)	Flanged Receptacle (sockets)	Plug (sockets)	Flanged Receptacle (pins)			
4	10	192993-0011	192993-0031	192993-0051	192993-0071	.055 (1.4) - .086 (2.2)	075-8543-011	192900-0639
† 4	10	192993-0001	192993-0021	192993-0041	192993-0061	No Wire Seal	075-8543-011	192900-0639
8	12	192993-0012	192993-0032	192993-0052	192993-0072	.055 (1.4) - .086 (2.2)	075-8543-012	192900-0640
† 8	12	192993-0002	192993-0022	192993-0042	192993-0062	No Wire Seal	075-8543-012	192900-0640
12	14	192993-0013	192993-0033	192993-0053	192993-0073	.055 (1.4) - .086 (2.2)	192900-0565	192900-0286
† 12	14	192993-0003	192993-0023	192993-0043	192993-0063	No Wire Seal	192900-0565	192900-0286
19	16	192993-0014	192993-0034	192993-0054	192993-0074	.055 (1.4) - .086 (2.2)	192900-0566	192900-0343
† 19	16	192993-0004	192993-0024	192993-0044	192993-0064	No Wire Seal	192900-0566	192900-0343

† Without wire seal but waterproof to IP67 when used with waterproof endbell.





192993-008\_



192993-009\_

## New Low Cost Shielded Gland Seal Endbell

In order to meet EMC requirements it is necessary to fit a shielded endbell to the TNM connector. The TNM Shielded Gland Seal Endbell provides for a simple and effective way to terminate, shield and properly seal round jacketed cables. Call for right angle extenders S4810. Call for dimensional drawings.

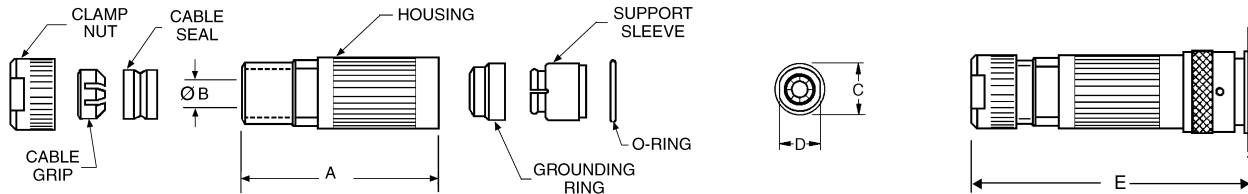

Shell Size	Part Number	A	B	C	D	E(Std.)	E(Rev.)
10	192993-0081	2.228 (56.6)	.315 (8.0)	.705 (17.9)	.512 (13.0)	3.484 (88.5)	3.150 (80.0)
12	192993-0082	2.232 (56.7)	.394 (10.0)	.827 (21.0)	.630 (16.0)	3.484 (88.5)	3.150 (80.0)
14	192993-0083	2.244 (57.0)	.449 (11.3)	.945 (24.0)	.748 (19.0)	3.484 (88.5)	3.150 (80.0)
16	192993-0084	2.260 (57.4)	.535 (13.6)	1.079 (27.4)	.866 (22.0)	3.484 (88.5)	3.150 (80.0)

### Assembly Instructions:

- Slide O ring over connector body and it will fit into a groove just past the accessory threading.
- Slide, clamp nut, cable clamp (Note cable clamp compression fingers point toward the connector body), gland seal, (Use isopropyl alcohol to slide rubber gland), metal endbell body, metal shielding cone and, plastic retention clip in that order over your jacketed cable.
- Strip back cable jacket as shown.
- Terminate and insert contacts per assembly instructions on [page 68](#).
- Slide plastic retention clip down onto the connector body.
- Pull braided cable shield over plastic ret. clip.
- Slide metal shielding cone down until it snaps on to the plastic retention clip. The shield should now be captivated between plastic retention clip and metal shielding cone.
- Fold remaining braided cable shield back over the metal shielding cone.
- Slide the metal endbell body down the cable and tighten by hand.
- Slide gland seal, cable clamp down into the back of the metal endbell. (Note isopropyl alcohol will assist in sliding rubber gland seal on cable).
- Snug up endbell with appropriate wrench and endbell assembly tools on [page 266](#).
- Push the cable grip up against the gland seal, then thread clamp nut onto endbell body and tighten to 10Nm+/-1Nm(88.50 inch/pounds).

Plastic Waterproof Gland Seal Endbell	Cable Jacket Sealing Range for Plastic Endbell inches (mm)	Shielded Metal Waterproof Gland Seal Endbell	Cable Jacket Sealing Range for Metal Shielded Endbell inches (mm)	Receptacle Metal Dust Cap	Receptacle Plastic Dust Cap	Metal Plug Dust Cap
192900-0636	.165(4.2)-.354(9.0)	192993-0081	.173(4.4)-.287(7.3)	192922-1480	192900-0376	MS3180-10CA
192900-0636	.165(4.2)-.354(9.0)	192993-0091	.196(5.0)-.393(10.0)	192922-1480	192900-0376	MS3180-10CA
192900-0637	.224(5.7)-.366(9.3)	192993-0082	.252(6.4)-.374(9.5)	192990-1490	192900-0377	MS3180-12CA
192900-0637	.224(5.7)-.366(9.3)	192993-0092	.236(6.0)-.472(12.0)	192990-1490	192900-0377	MS3180-12CA
192900-0496	.256(6.5)-.488(12.4)	192993-0083	.272(6.9)-.402(10.2)	192922-1500	192900-0378	MS3180-14CA
192900-0496	.256(6.5)-.488(12.4)	192993-0093	.275(7.0)-.551(14.0)	192922-1500	192900-0378	MS3180-14CA
192900-0497	.256(6.5)-.630(16.0)	192993-0084	.311(7.9)-.496(12.6)	192922-1510	192900-0379	MS3180-16CA
192900-0497	.256(6.5)-.630(16.0)	192993-0094	.314(8.0)-.629(16.0)	192922-1510	192900-0379	MS3180-16CA

# Dimensions

## TNM Standard Plug

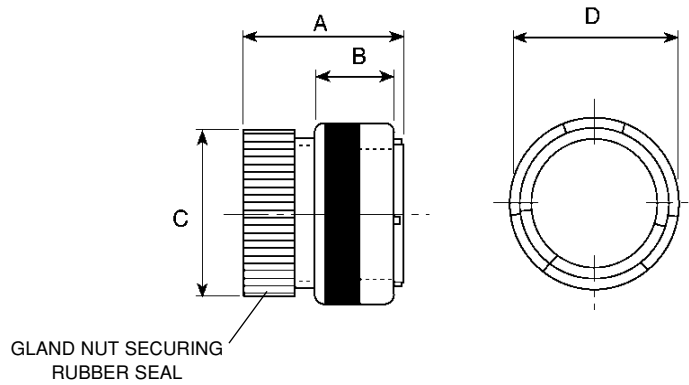

Number of Contacts	Shell Size	Part Number	A	B	C	D
4	10	192993-0011	1.673 (42.5)	.580 (14.7)	.689 (17.5)	.850 (21.6)
† 4	10	192993-0001	1.500 (38.1)	.580 (14.7)	.543 (13.8)	.850 (21.6)
8	12	192993-0012	1.673 (42.5)	.580 (14.7)	.811 (20.6)	.976 (24.8)
† 8	12	192993-0002	1.500 (38.1)	.580 (14.7)	.665 (16.9)	.976 (24.8)
12	14	192993-0013	1.673 (42.5)	.580 (14.7)	.957 (24.3)	1.102 (28.0)
† 12	14	192993-0003	1.500 (38.1)	.580 (14.7)	.791 (20.1)	1.102 (28.0)
19	16	192993-0014	1.673 (42.5)	.580 (14.7)	1.063 (27.0)	1.229 (31.2)
† 19	16	192993-0004	1.500 (38.1)	.580 (14.7)	.917 (23.3)	1.229 (31.2)

† Dimensions without wire seal and standard wire seal endbell

## TNM Standard Flanged Receptacles

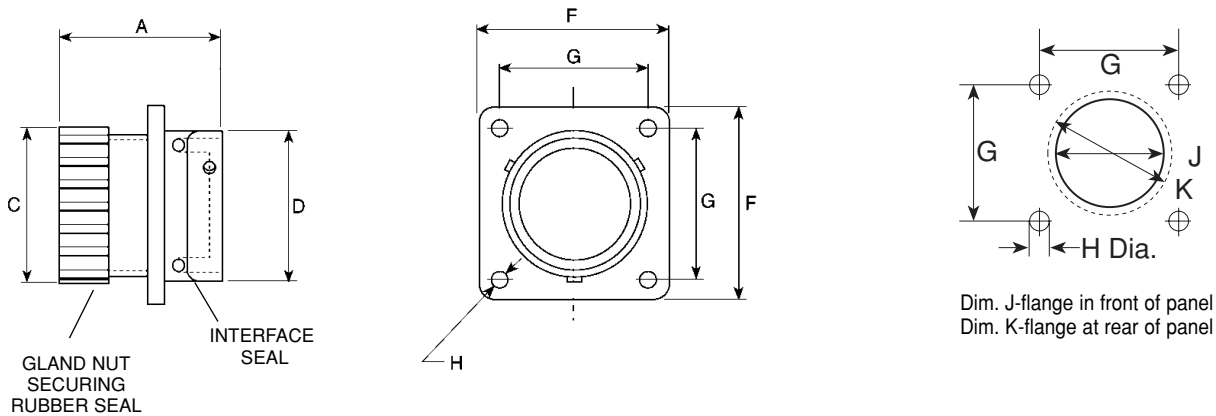

Number of Contacts	Shell Size	Part Number	A	C	D	F	G	H	J	K
4	10	192993-0031	1.366 (34.7)	.689 (17.5)	.587 (14.92)	.937 (23.79)	.719 (18.26)	.126 (3.2)	.594 (15.1)	.681 (17.3)
† 4	10	192993-0021	1.193 (30.3)	.563 (14.3)	.587 (14.92)	.937 (23.79)	.719 (18.26)	.126 (3.2)	.594 (15.1)	.681 (17.3)
8	12	192993-0032	1.366 (34.7)	.811 (20.6)	.747 (18.98)	1.030 (26.15)	.812 (20.62)	.126 (3.2)	.717 (18.2)	.858 (21.8)
† 8	12	192993-0022	1.193 (30.3)	.685 (17.4)	.747 (18.98)	1.030 (26.15)	.812 (20.62)	.126 (3.2)	.717 (18.2)	.858 (21.8)
12	14	192993-0033	1.366 (34.7)	.957 (24.3)	.872 (22.16)	1.124 (28.54)	.898 (22.80)	.138 (3.5)	.843 (21.4)	.984 (25.0)
† 12	14	192993-0023	1.193 (30.3)	.811 (20.6)	.872 (22.16)	1.124 (28.54)	.898 (22.80)	.138 (3.5)	.843 (21.4)	.984 (25.0)
19	16	192993-0034	1.366 (34.7)	1.063 (27.0)	.997 (25.33)	1.216 (30.89)	.969 (24.61)	.138 (3.5)	.969 (24.6)	1.106 (28.1)
† 19	16	192993-0024	1.193 (30.3)	.937 (23.8)	.997 (25.33)	1.216 (30.89)	.969 (24.61)	.138 (3.5)	.969 (24.6)	1.106 (28.1)

† Dimensions without wire seal and standard wire seal endbell

# Dimensions

## TNM Reversed Plug

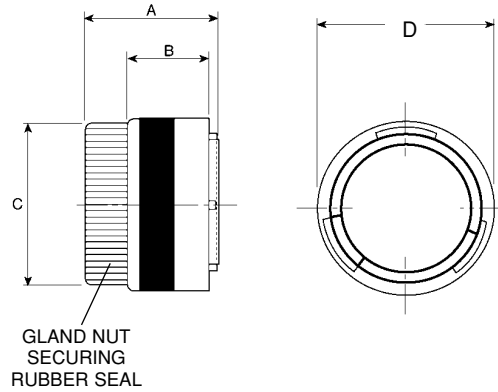

Number of Contacts	Shell Size	Part Number	A	B	C	D
4	10	192993-0051	1.346 (34.2)	.580 (14.7)	.689 (17.5)	.850 (21.6)
† 4	10	192993-0041	1.173 (29.8)	.580 (14.7)	.543 (13.8)	.850 (21.6)
8	12	192993-0052	1.346 (34.2)	.580 (14.7)	.811 (20.6)	.976 (24.8)
† 8	12	192993-0042	1.173 (29.8)	.580 (14.7)	.665 (16.9)	.976 (24.8)
12	14	192993-0053	1.346 (34.2)	.580 (14.7)	.957 (24.3)	1.102 (28.0)
† 12	14	192993-0043	1.173 (29.8)	.580 (14.7)	.791 (20.1)	1.102 (28.0)
19	16	192993-0054	1.346 (34.2)	.580 (14.7)	1.063 (27.0)	1.229 (31.2)
† 19	16	192993-0044	1.173 (29.8)	.580 (14.7)	.917 (23.3)	1.229 (31.2)

† Dimensions without wire seal and standard wire seal endbell

## TNM Reversed Flanged Receptacles

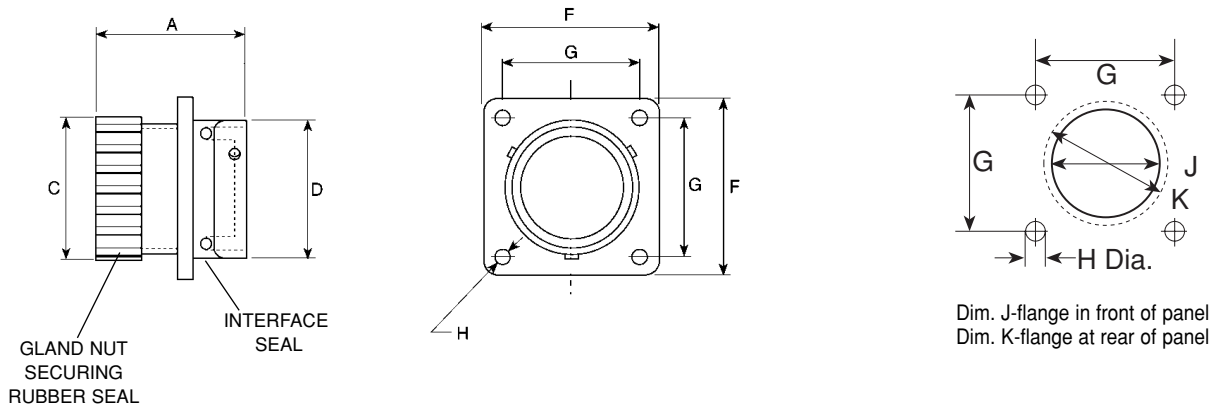

Number of Contacts	Shell Size	Part Number	A	C	D	F	G	H	J	K
4	10	192993-0071	1.693 (43.0)	.689 (17.5)	.587 (14.92)	.937 (23.79)	.719 (18.26)	.126 (3.2)	.594 (15.1)	.681 (17.3)
† 4	10	192993-0061	1.520 (38.6)	.563 (14.3)	.587 (14.92)	.937 (23.79)	.719 (18.26)	.126 (3.2)	.594 (15.1)	.681 (17.3)
8	12	192993-0072	1.693 (43.0)	.811 (20.6)	.747 (18.98)	1.030 (26.15)	.812 (20.62)	.126 (3.2)	.717 (18.2)	.858 (21.8)
† 8	12	192993-0062	1.520 (38.6)	.685 (17.4)	.747 (18.98)	1.030 (26.15)	.812 (20.62)	.126 (3.2)	.717 (18.2)	.858 (21.8)
12	14	192993-0073	1.693 (43.0)	.957 (24.3)	.872 (22.16)	1.124 (28.54)	.898 (22.80)	.138 (3.5)	.843 (21.4)	.984 (25.0)
† 12	14	192993-0063	1.520 (38.6)	.811 (20.6)	.872 (22.16)	1.124 (28.54)	.898 (22.80)	.138 (3.5)	.843 (21.4)	.984 (25.0)
19	16	192993-0074	1.693 (43.0)	1.063 (27.0)	.997 (25.33)	1.216 (30.89)	.969 (24.61)	.138 (3.5)	.969 (24.6)	1.106 (28.1)
† 19	16	192993-0064	1.520 (38.6)	.937 (23.8)	.997 (25.33)	1.216 (30.89)	.969 (24.61)	.138 (3.5)	.969 (24.6)	1.106 (28.1)

† Dimensions without wire seal and standard wire seal endbell

# Dimensions

## Standard Plug

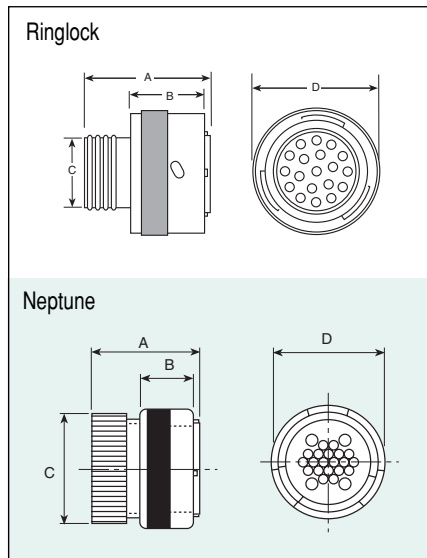

Layout	Shell Size	Standard Plug	A	B	C	D
0-4	10	192922-1250	1.252	0.756	0.429	0.850
0-7	18	192922-1330	1.299	0.756	0.885	1.350
0-8	12	192922-1260	1.252	0.756	0.543	0.976
0-12	14	192922-1270	1.252	0.756	0.669	1.102
0-12	14	192900-0303	1.527	0.756	0.956	1.102
2-13	16	192900-0507	1.566	0.751	1.063	1.189
0-19	16	192922-1280	1.252	0.751	0.783	1.228
0-19	16	192900-0017	1.566	0.756	1.063	1.189
0-23	18	192990-1320	1.252	0.756	0.881	1.350
4-20	24	192900-0014	1.566	0.580	1.594	1.732
0-28	20	192922-1290	1.252	0.751	1.007	1.476
12-19	24	192900-0016	1.566	0.756	1.594	1.732
4-28	24	192900-0015	1.566	0.756	1.594	1.732
0-35	22	192922-1300	1.252	0.580	1.122	1.602
0-48	24	192990-1340	1.252	0.756	1.248	1.728
0-48	24	192900-0469	1.566	0.756	1.594	1.732
0-48 (L)	24	192991-0628	2.000	0.756	1.594	1.732

All dimensions are in inches

## Standard Flanged Receptacle

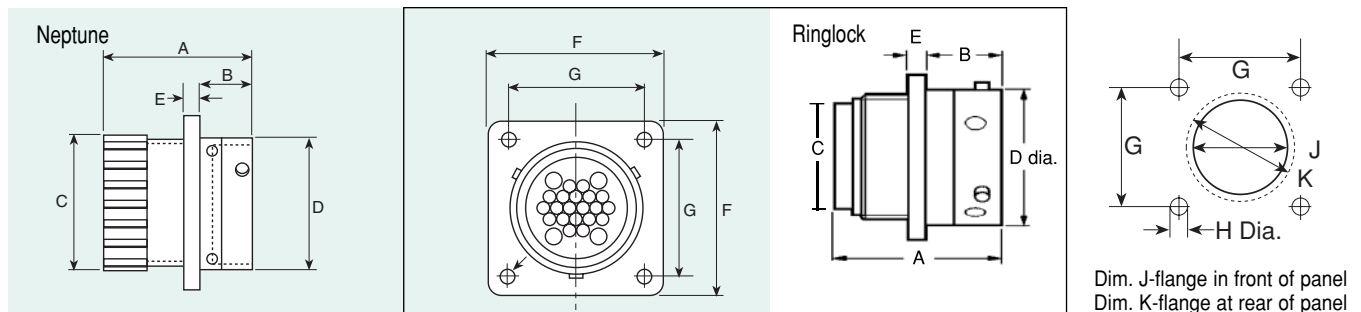

Dim. J-flange in front of panel  
Dim. K-flange at rear of panel

Layout	Shell Size	Standard Flanged Receptacle	A	B	C	D	E	F	G	H	J	K
0-4	10	192990-1660	1.016	0.439	0.433	0.591	0.091	0.925	0.709	0.128	0.594	0.681
0-7	8	192990-1700	1.280	0.716	0.886	1.122	0.098	1.311	1.063	0.128	1.094	1.232
0-8	12	192990-1670	1.016	0.447	0.547	0.748	0.091	1.031	0.807	0.128	0.717	0.858
0-12	14	192990-1680	1.016	0.447	0.673	0.874	0.091	1.108	0.890	0.128	0.842	0.984
0-12	14	192900-0308	1.563	0.448	0.956	0.874	0.091	1.122	0.901	0.126	0.968	0.968
2-13	16	192900-0509	1.566	0.448	1.063	1.000	0.091	1.220	0.964	0.126	1.106	1.106
0-19	16	192990-1690	1.016	0.447	0.787	1.000	0.091	1.200	0.953	0.128	0.968	1.106
0-19	16	192900-0039	1.566	0.448	1.063	1.000	0.091	1.220	0.964	0.126	1.106	1.106
0-23	18	192990-1710	1.016	0.447	0.886	1.122	0.098	1.311	1.059	0.128	1.094	1.232
4-20	24	192900-0030	1.645	0.606	1.578	1.500	0.138	2.000	1.563	0.165	1.614	1.614
0-28	20	192990-1720	1.311	0.571	1.012	1.248	0.098	1.437	1.150	0.128	1.216	1.358
12-19	24	192900-0036	1.645	0.606	1.578	1.500	0.138	2.000	1.563	0.165	1.614	1.614
4-28	24	192900-0033	1.645	0.606	1.578	1.500	0.138	2.000	1.563	0.165	1.614	1.614
0-35	22	192990-1730	1.311	0.571	1.126	1.374	0.138	1.563	1.244	0.128	1.342	1.484
0-48	24	192990-1740	1.311	0.602	1.252	1.500	0.138	1.689	1.356	0.154	1.468	1.610
0-48	24	192900-0475	1.645	0.606	1.578	1.500	0.138	2.000	1.563	0.165	1.614	1.614
0-48 (L)	24	192991-0640	2.075	0.606	1.578	1.500	0.138	2.000	1.563	0.165	1.614	1.614

All dimensions are in inches

# Dimensions

## Standard Jam Nut Receptacle

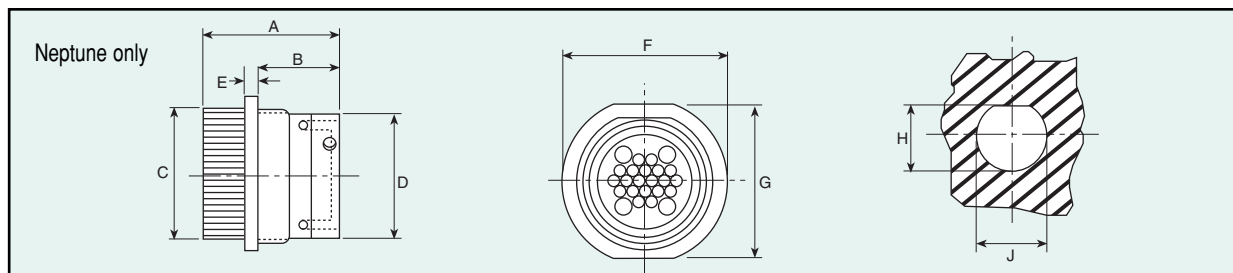

Layout	Shell Size	Standard Jam Nut Receptacle	A	B	C	D	E	F	G	H	J
0-12	14	192900-0313	1.563	0.870	0.956	0.874	0.138	1.410	1.267	0.988	1.075
0-19	16	192900-0490	1.565	0.905	1.063	1.000	0.090	1.566	1.511	1.102	1.200
2-13	16	192900-0508	1.565	0.905	1.063	1.000	0.090	1.566	1.511	1.102	1.200
4-20	24	192900-0032	1.646	0.921	1.579	1.500	0.138	2.008	1.870	1.634	1.701
12-19	24	192900-0038	1.646	0.921	1.579	1.500	0.138	2.008	1.870	1.634	1.701
4-28	24	192900-0035	1.646	0.921	1.579	1.500	0.138	2.008	1.870	1.634	1.701
0-48 (L)	24	192991-0644	2.075	0.921	1.579	1.500	0.138	2.008	1.870	1.634	1.701
0-48	24	192900-0481	1.646	0.921	1.579	1.500	0.138	2.008	1.870	1.634	1.701

All dimensions are in inches

## Reverse Plug

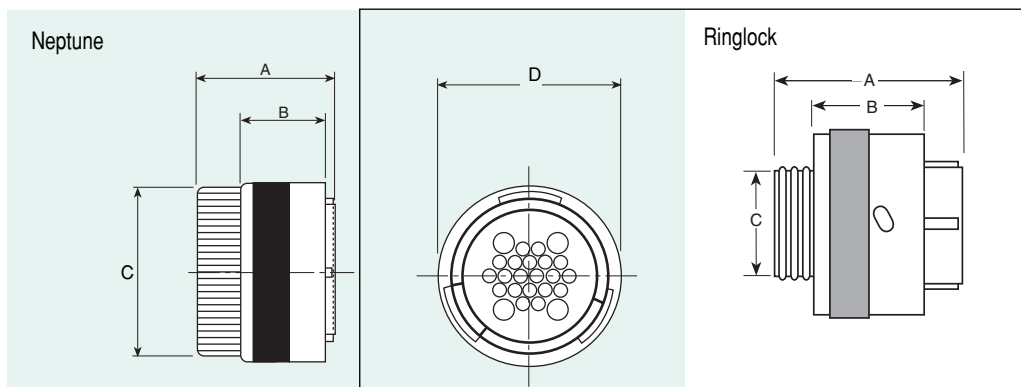

Layout	Shell Size	Reverse Plug	A	B	C	D
0-4	10	192926-0500	1.027	0.752	0.433	0.850
0-8	12	192926-0510	1.008	0.752	0.547	0.976
0-12	14	192926-0520	1.055	0.752	0.673	1.102
0-12	14	192900-0236	1.244	0.752	0.957	1.102
0-19	16	192926-0530	1.087	0.752	0.787	1.228
0-19	16	192900-0057	1.248	0.752	1.063	1.189
2-13	16	192900-0581	1.248	0.752	1.063	1.189
0-7	18	192990-1390	1.240	0.752	0.885	1.350
0-23	18	192990-1380	1.008	0.752	0.885	1.350
0-28	20	192926-0540	1.232	0.752	1.011	1.476
0-35	22	192926-0550	1.232	0.752	1.126	1.602
4-20	24	192900-0054	1.275	0.580	1.594	1.732
12-19	24	192900-0056	1.275	0.580	1.594	1.732
4-28	24	192900-0055	1.275	0.580	1.594	1.732
0-48 (L)	24	192991-0648	1.693	0.580	1.594	1.732
0-48	24	192900-0425	1.275	0.580	1.594	1.732
0-48	24	192990-1400	1.232	0.580	1.225	1.728

All dimensions are in inches

# Dimensions

## Reverse Flanged Receptacle

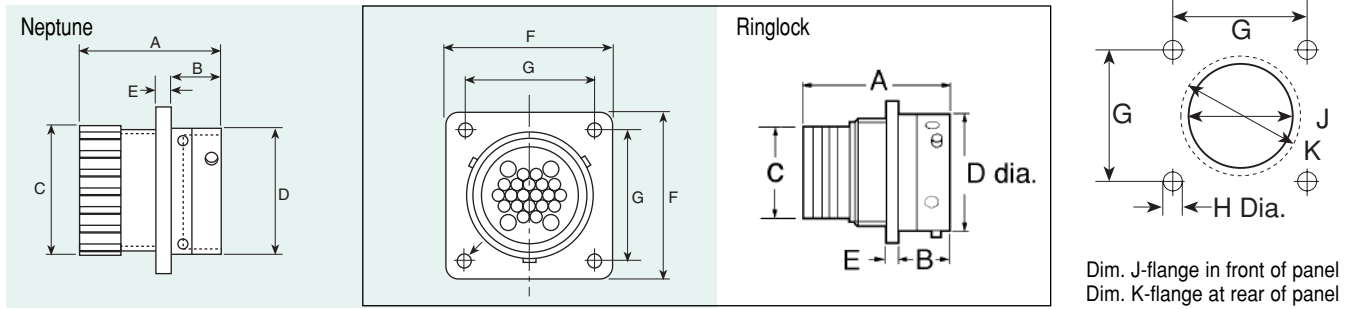

Layout	Shell Size	Reverse Flanged Receptacle	A	B	C	D	E	F	G	H	J	K
0-4	10	192990-1760	1.240	0.447	0.433	0.591	0.091	0.925	0.709	0.128	0.594	0.681
0-7	18	192990-1800	1.346	0.700	0.886	1.122	0.091	1.311	1.063	0.128	1.094	1.232
0-8	12	192990-1770	1.240	0.447	0.547	0.748	0.091	1.031	0.807	0.128	0.717	0.858
0-12	14	192990-1780	1.240	0.447	0.673	0.874	0.091	1.108	0.890	0.128	0.843	0.984
0-12	14	192900-0256	1.563	0.448	0.956	0.874	0.090	1.122	0.901	0.126	0.968	0.968
2-13	16	192900-0582	1.566	0.448	1.063	1.000	0.090	1.220	0.964	0.126	1.106	1.106
0-19	16	192990-1790	1.240	0.447	0.787	1.000	0.091	1.200	0.953	0.128	0.969	1.106
0-19	16	192900-0078	1.566	0.448	1.063	1.000	0.090	1.220	0.964	0.126	1.106	1.106
0-23	18	192990-1810	1.240	0.447	0.886	1.122	0.098	1.311	1.059	0.128	1.094	1.232
4-20	24	192900-0069	1.646	0.606	1.578	1.500	0.137	2.000	1.563	0.165	1.614	1.614
0-28	20	192990-1820	1.299	0.573	1.012	1.248	0.098	1.437	1.150	0.128	1.217	1.358
12-19	24	192900-0075	1.646	0.606	1.578	1.500	0.137	2.000	1.563	0.165	1.614	1.614
4-28	24	192900-0072	1.646	0.606	1.578	1.500	0.137	2.000	1.563	0.165	1.614	1.614
0-35	22	192990-1830	1.299	0.573	1.126	1.374	0.138	1.563	1.244	0.128	1.343	1.484
0-48	24	192990-1840	1.370	0.604	1.252	1.498	0.138	1.689	1.356	0.154	1.469	1.610
0-48	24	192900-0431	1.646	0.606	1.578	1.500	0.137	2.000	1.563	0.165	1.614	1.614
0-48 (L)	24	192991-0652	2.075	0.606	1.578	1.500	0.137	2.000	1.563	0.165	1.614	1.614

All dimensions are in inches

## Reverse Jam Nut Receptacle

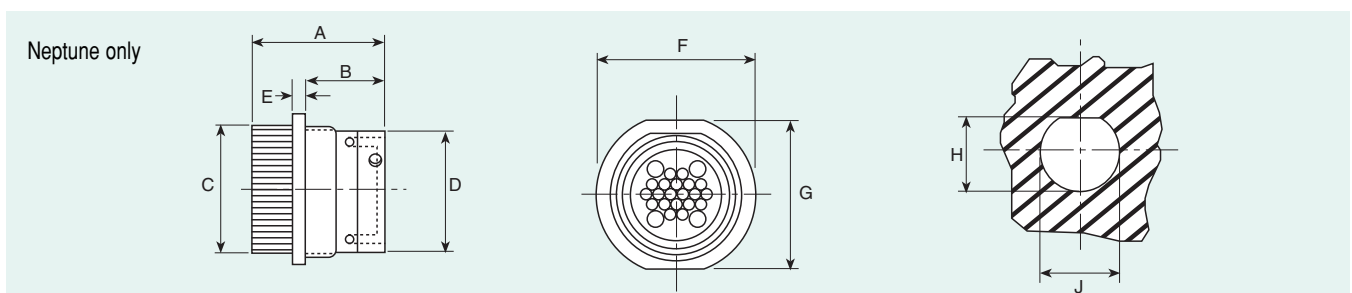

Layout	Shell Size	Reverse Jam Nut Receptacle	A	B	C	D	E	F	G	H	J
0-12	14	192900-0266	1.563	0.870	0.956	0.874	0.137	1.409	1.267	0.988	1.075
2-13	16	192900-0583	1.566	0.905	1.063	1.000	0.090	1.212	1.503	1.102	1.200
0-19	16	192900-0353	1.566	0.905	1.063	1.000	0.090	1.212	1.503	1.102	1.200
4-20	24	192900-0071	1.645	0.921	1.578	1.500	0.137	2.007	1.870	1.633	1.700
12-19	24	192900-0077	1.645	0.921	1.578	1.500	0.137	2.007	1.870	1.633	1.700
4-28	24	192900-0074	1.645	0.921	1.578	1.500	0.137	2.007	1.870	1.633	1.700
0-48	24	192900-0437	1.646	0.921	1.578	1.500	0.137	2.007	1.870	1.633	1.700
0-48 (L)	24	192991-0656	2.075	0.921	1.578	1.500	0.137	2.007	1.870	1.633	1.700

All dimensions are in inches

# Dimensions

## Sealed Cable Clamps for use with Jacketed Cables

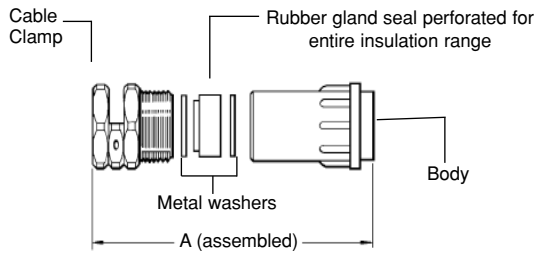

\* For disassembly add .354 (9.0) for Shell Sizes 10-16 & .417 (10.6) for Shell Sizes 18-24

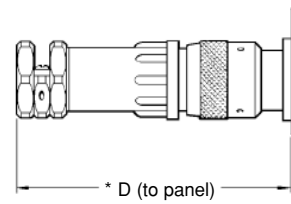

Shell Size	Part #	Dimensions				Wire Sealing Diameter Inches (mm)		Rear Thread
		A Max	B Max	C± .007 (.20)	D Max	Max.	Min.	
10	192990-1530	2.165 (55.0)	.437 (11.1)	.740 (18.8)	3.011 (76.5)	.354 (9.0)	.165 (4.2)	PG 9
12	192990-1540	2.283 (58.0)	.535 (13.6)	.818 (20.8)	3.063 (77.8)	.366 (9.3)	.224 (5.7)	PG 11
14	192990-1550	2.559 (65.0)	.574 (14.6)	.897 (22.8)	3.366 (85.5)	.488 (12.4)	.256 (6.5)	PG 13.5
14	192900-0496	2.559 (65.0)	.574 (14.6)	.897 (22.8)	3.366 (85.5)	.488 (12.4)	.256 (6.5)	PG 13.5
16	192990-1560	2.716 (69.0)	.653 (16.6)	.972 (24.7)	3.535 (89.8)	.488 (12.4)	.256 (6.5)	PG 16
16	192900-0497	2.716 (69.0)	.653 (16.6)	.972 (24.7)	3.535 (89.8)	.488 (12.4)	.256 (6.5)	PG 16
18	192990-1570	2.874 (73.0)	.653 (16.6)	.972 (24.7)	3.661 (93.0)	.630 (16.0)	.256 (6.5)	PG 16
20	192990-1580	3.267 (83.0)	.870 (22.1)	1.252 (31.8)	4.232 (107.5)	.748 (19.0)	.362 (9.2)	PG 21
22	192990-1590	3.543 (90.0)	.870 (22.1)	1.252 (31.8)	4.507 (114.5)	.748 (19.0)	.362 (9.2)	PG 21
24	192990-1600	4.133 (105.0)	1.165 (29.6)	1.645 (41.8)	5.059 (128.5)	1.040 (26.5)	.670 (17.0)	PG 29
24	192900-0498	4.133 (105.0)	1.165 (29.6)	1.645 (41.8)	5.059 (128.5)	1.040 (26.5)	.670 (17.0)	PG 29

## Unsealed Cable Clamps - Strain Relief and Wire Protection

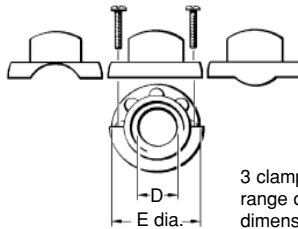
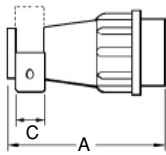

\* For disassembly add .354 (9.0) for Shell Sizes 10-16 & .417 (10.6) for Shell Sizes 18-24

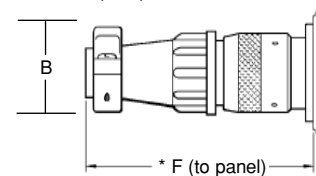

Shell Size	Part #	Dimensions					
		A± .005 (.15)	B Max	C± .005 (.15)	D Max	E± .005 (.15)	F Max
10	192922-1310	1.570 (39.9)	.846 (21.5)	.251 (6.4)	.342 (8.7)	.826 (21.0)	2.413 (61.3)
12	192922-1320	1.574 (40.0)	.980 (24.9)	.251 (6.4)	.503 (12.8)	.944 (24.0)	2.413 (61.3)
14	192922-1330	1.811 (46.0)	1.063 (27.0)	.251 (6.4)	.543 (13.8)	1.063 (27.0)	2.641 (67.1)
14	192900-0286	1.811 (46.0)	1.063 (27.0)	.251 (6.4)	.543 (13.8)	1.063 (27.0)	2.641 (67.1)
16	192922-1340	1.811 (46.0)	1.185 (30.1)	.251 (6.4)	.669 (17.0)	1.189 (30.2)	2.641 (67.1)
16	192900-0343	1.811 (46.0)	1.185 (30.1)	.251 (6.4)	.669 (17.0)	1.189 (30.2)	2.641 (67.1)
18	192922-1510	1.968 (50.0)	1.259 (32.0)	.275 (7.0)	.783 (19.9)	1.307 (33.2)	2.787 (70.8)
20	192922-1350	2.165 (55.0)	1.350 (34.3)	.275 (7.0)	.826 (21.0)	1.433 (36.4)	3.122 (79.3)
22	192922-1360	2.362 (60.0)	1.460 (37.1)	.322 (8.2)	.905 (23.0)	1.559 (39.6)	3.358 (85.3)
24	192922-1520	2.559 (65.0)	1.645 (41.8)	.322 (8.2)	1.063 (27.0)	1.685 (42.8)	3.574 (90.8)
24	192900-0344	2.559 (65.0)	1.645 (41.8)	.322 (8.2)	1.102 (28.0)	1.673 (42.5)	3.574 (90.8)

## Ringlock Adapters for Heat Shrink Boots or Sleeving

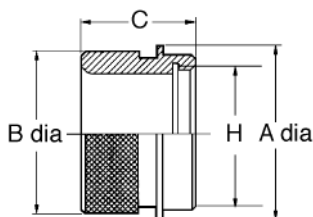

Shell Size	Part #	Dimensions (Max)			
		A	B	C	H Thread
10	192990-1430	.827 (21.0)	.712 (18.1)	.755 (19.2)	9/16-24UNEF-2B
12	192990-1440	.944 (24.0)	.921 (23.4)	.755 (19.2)	11/16-24UNEF-2B
14	192990-1450	1.063 (27.0)	.952 (24.2)	.755 (19.2)	13/16-20UNEF-2B
16	192990-1460	1.189 (30.2)	1.165 (29.6)	.846 (21.5)	15/16-20UNEF-2B
18	192990-1470	1.311 (33.3)	1.248 (31.7)	.846 (21.5)	1-1/16-18UNEF-2B
20	192990-1480	1.437 (36.5)	1.409 (35.8)	.897 (22.8)	1-3/16-18UNEF-2B
22	192990-1490	1.563 (39.7)	1.503 (38.2)	.897 (22.8)	1-5/16-18UNEF-2B
24	192990-1500	1.689 (42.9)	1.626 (41.3)	.862 (21.9)	1-7/16-18UNEF-2B

## 1. Crimp Tool Operation

There are five different crimp tools used with Trident contacts. Find the appropriate tool on the Contact Selection Chart and follow the instructions for that tool below.

### Hand Crimp Tool for Stamped Contacts

(192990-3140 for 16-28 AWG contacts and 192900-0175 for 14 AWG contacts)

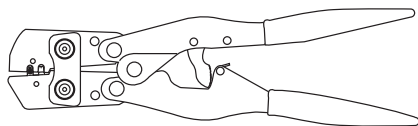

1. Strip wires to length (See strip lengths in Column 8 of contact chart, [page 59](#)).
2. Open the tool and select the proper crimp cavity for the wire gauge.
3. Hold tool in your right hand with the die cavity identification away from you.
4. Pick up the contact by the mating end. Slip the contact into the appropriate die cavity so that the notch just behind the "gold" portion of the contact fits over the sliding plate on the lower half of the die.
5. Squeeze the handle just enough to hold the contact in the die cavity.
6. Turn the tool over in your right hand and insert the stripped wire into the contact until it bottoms.
7. Cycle the tool. The tool will not open until the contact has been completely crimped.
8. Inspect the crimp. See "Stamped Contacts" in Crimp Inspection section on [page 70](#). A contact crimp verification tool is available. Please call.

### Contacts Crimp Tool

(121586-5236)  
(121586-5237)  
(121586-5238)

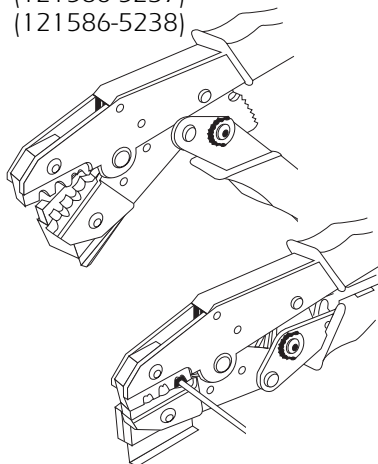

1. Strip wires to length (See strip lengths in Column 8 of contact chart, [page 59](#)).
2. Open the tool and select the proper crimp cavity for the wire gauge.
3. Now hold the tool so that cavity identification is away from you (the back side).
4. Surrounding the lower die is a holding frame. Push up on the tab to fully raise the frame.
5. While holding the frame open, insert the power contact, wire side first, until the lip on the contact butts against the ledge of the lower die. The U shaped wire crimps should be upright in the die.
6. Release the tab. The frame should now be holding the contact in the proper cavity, ready to crimp.
7. Close the tool just enough to grip the contact.
8. Insert the stripped wire into the contact from the wire side.
9. Cycle the tool. The tool will not open until the contact has been completely crimped. An escape lever is located on the ratchet mechanism to release the tool if necessary.
10. Inspect the crimp. See "Stamped Contacts" in Crimp Inspection section on [page 70](#).

### Economy Tool for Stamped Contacts

(192922-1440)

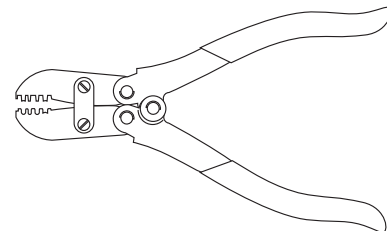

1. Strip wires to length (See strip lengths in Column 8 of contact chart, [page 59](#)).
2. Select the proper crimp cavity for the wire gauge.
3. The contact itself has two U shaped crimp areas, each requiring a separate crimp operation. The larger, rear U shape area crimps over the wire insulation and provides strain relief. The smaller, longer, U shape area crimps over the bare wire and provides the electrical connection.
4. Insert the contact into the tool so that the smaller wire crimp U is upright and centered in the proper die (the open portion of the U facing the cavity identification on the tool).
5. Close the tool just enough to firmly grip the contact.
6. Insert the stripped wire into the contact until it bottoms.
7. Cycle the tool.
8. Remove the crimped contact. Now you must crimp the insulation grip.
9. Place the insulation U upright in the die cavity marked INS. Crimp the Insulation U over the wire insulation in the same manner as the wire crimp.
10. Inspect the two crimps. See "Stamped Contacts" in Crimp Inspection section on [page 70](#). A contact crimp verification tool is available. Please call.



## Crimp Tool for Machined Contacts

(AF8 Tool and TH206 Turret)

- Strip the wires to length. See strip lengths in Column 8 of the contact chart, [page 59](#).
- Open the crimp tool by squeezing the handles. Push the latch on turret to pop up the locator. Attach the turret to the crimp tool using the two captive hex bolts in the turret.

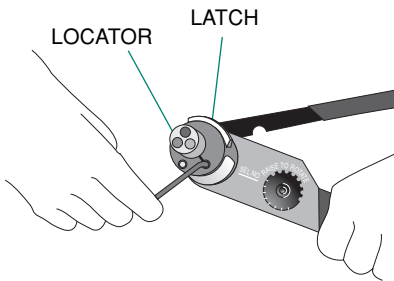

- Select the proper locator position for your contact by rotating the locator until the proper color is aligned with the index mark. Push locator back down until it snaps into position.

CONTACT TYPE	LOCATOR COLOR
PINS	BLUE
SOCKETS	GREEN
FIRST-MAKE	BLACK

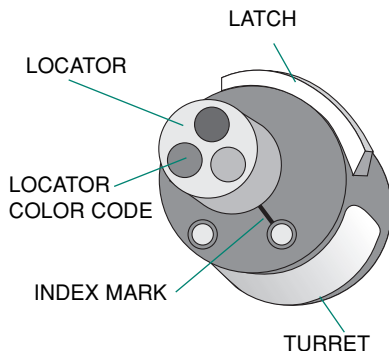

➔ [See Trident Coax Contact Assembly](#)

- Adjust dial for proper wire gauge. To change the dial setting, remove the lock pin and lift center of dial. Turn to the desired wire gauge. Replace lock pin on dial.

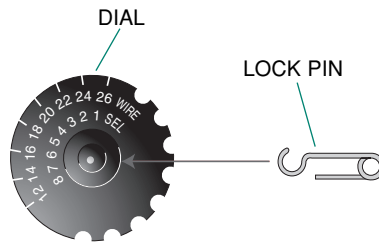

- Cycle the tool before inserting the contact to be sure the tool is in the open position. Drop the contact, mating end first, into the crimp cavity of the tool. Squeeze the tool handle just enough to grip the contact without actually crimping it.

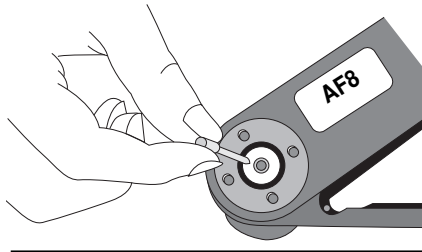

- Insert the stripped wire into the contact with a slight twisting motion. Be sure all wire strands are inside the contact. Squeeze the handle to cycle the tool. The handle will not release until the contact is completely crimped.

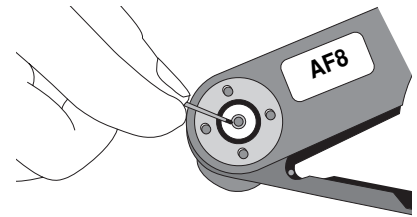

- Remove the crimped contact. Pull on the wire slightly to be sure it is properly crimped. Be sure the contact is not bent or damaged in any way.
- Visually inspect the crimp. See "machined contacts" drawing in Visual Check section on next page.

## New Trident Automatic Crimp tools for reeled stamped contacts

**NEW!**

Mini Applicators modules are used in industry standard crimp presses. This allows for fast change over for crimping different contacts and by using the same crimp press, saves valuable factory floor space versus having to use multiple presses.

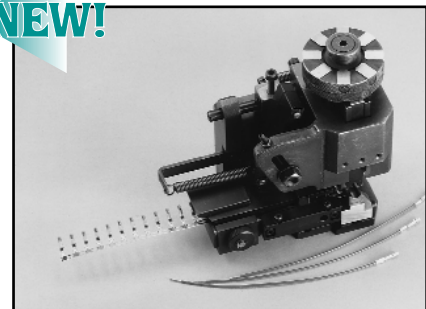

CONTACT	TYPE	MINI APPLICATOR PART NUMBER	
		METCAL	SCHAFFER
20-26	Signal	121586-5240	Call for Details
16-18	Signal	121586-5217	121586-5141
14-16	Signal	121586-5239	121586-5142

Adjustment fixture for signal applicators 317-8675-133

CONTACT	TYPE	MINI APPLICATOR PART NUMBER
16-18	Power	193800-0031
14-16	Power	193800-0024
12-14	Power	193800-0023

Call for detailed crimp specifications.

## 2. Crimp Inspection

### Micro sections

Enlargement of micro section allows for final judgment of crimp quality. This test is recommended whenever new tools or new types of wire are used.

### For stamped contacts

#### Correct Crimp

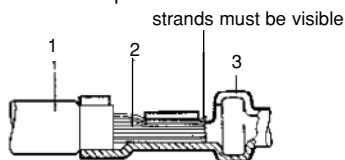

#### Incorrect Crimp

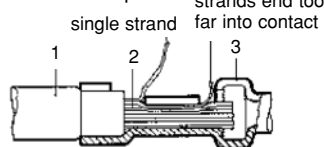

#### Incorrect Crimp

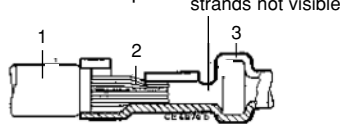

1 insulation / 2 strands / 3 contact

- 1 insulation
- 2 strands
- 3 contact
- 4 wire inspection hole
- 5 shoulder

### For machined contacts

#### Correct Crimp

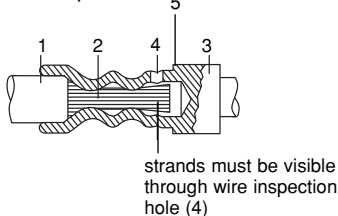

#### Incorrect Crimp

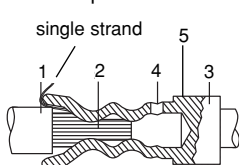

## 3. Insertion of Contacts

No insertion tool is required.

1. Grasp the wired contact just behind the insulation crimp and push firmly into the cavity until the contact locks into place. Give a slight pull to be sure the contact is seated.
2. When using Neptune connectors with the rear wire sealing grommet, put the grommet in place on the connector and push the contact directly through the grommet into the cavity. Start at the center of the layout and work concentrically to the outside edge to eliminate the possibility of the grommet shifting or bunching during loading.

Wire needles may be used as an assembly aid for use with high density layouts, maximum size wire insulation, or when adding to already terminated connectors.

For socket contact order: 192900-0606 - signal

For pin contact order: 192900-0605 - signal

For socket contact order: 192900-0608 - power

For pin contact order: 192900-0607 - power

To use, push the point of the needle through the hole selected and check that it has passed through to the correct contact cavity by looking at the mating face of the connector. Once verified, attach the contact to the non-pointed end of the needle. Holding the point of the contact, push the contact into the connector body until the contact locks into place. Note: The wiring needle is used as a guide and will not pull the contact into the connector body. Be sure to inspect the mating face (see 3 below) as the grommet mutes the "feel" of the contact locking into place.

3. Inspect by looking at the mating side of the connector. Be sure that all of the contacts are on the same plane (fully inserted). If not, use the extraction tool to remove the contact and re-insert.

## 4. Extraction of Contacts

Contacts can be removed from the housings using the appropriate extraction tool from Column 15 of the contact chart, [page 59](#). The tool is placed over the mating end of the contact and the sleeve is rotated slightly as it is pushed into the connector.

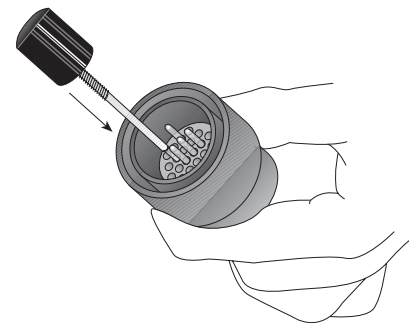

**IMPORTANT:** Make sure the depth indicating line on the tool is even with the mating face of the connector before depressing the plunger to avoid damage to connector and contact. Light pressure on the plunger then ejects the contact from the rear of the connector.

